



PARTS MANUAL

JCPT 3.0 (III)
ELECTRIC SCISSOR LIFTS



JCPT3.0(III)

Green - used to indicate operation or maintenance information.

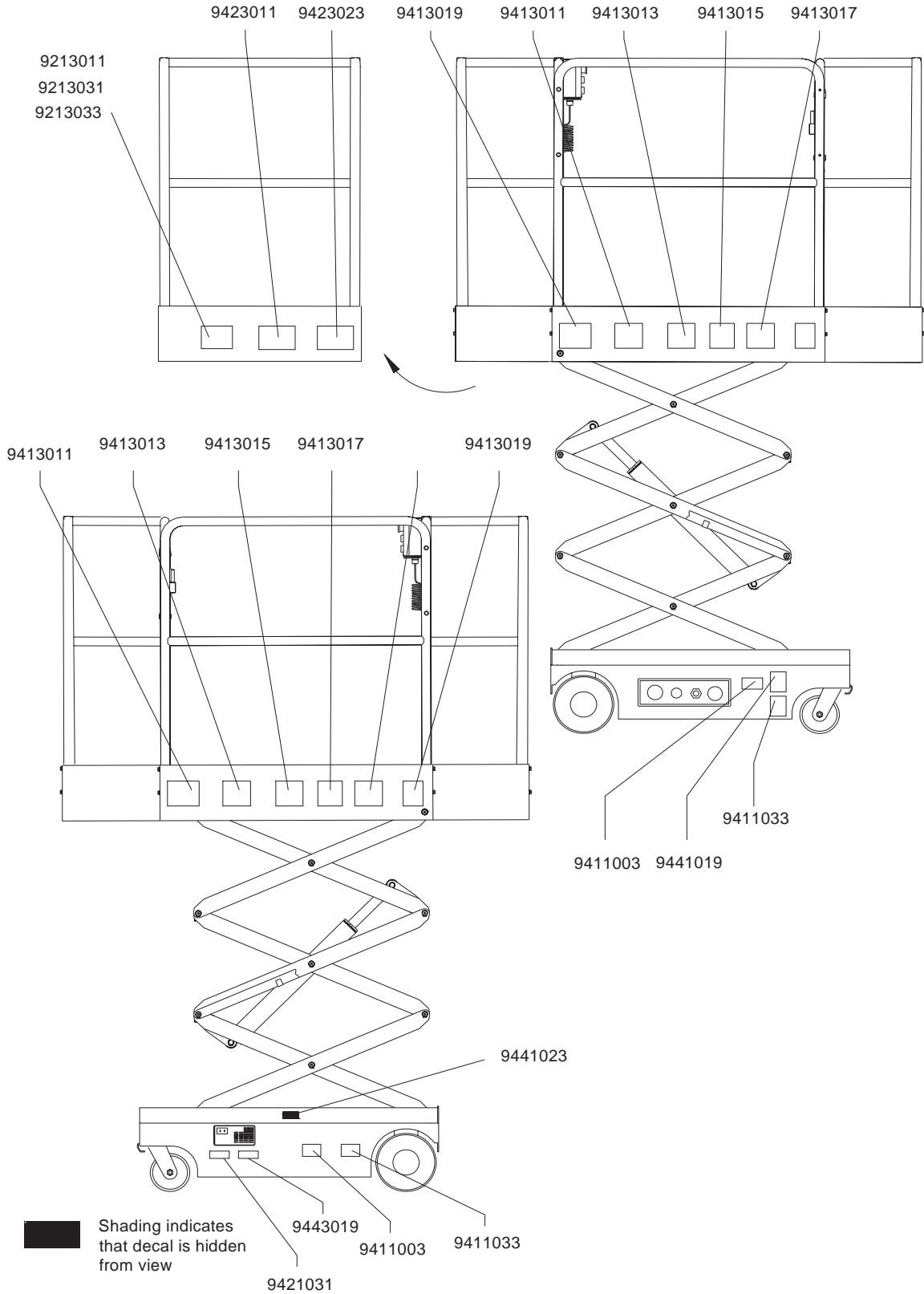

Decal Inspection

Use the pictures on the next page to verify that all decals are legible and in place.

Below is a numerical list with quantities and descriptions.

9213011	Label-Maximum Capacity 240kg	1
9213031	Label-Maximum Capacity 240kg (One extension deck)	1
9213033	Label-Maximum Capacity 240kg (Double extension deck)	1
9423011	Allowed number of person: 1	1
9423023	Maximum allowed manual force: 200N	1
9411003	Danger-Crushing Hazard	2
9413011	Warning-Tip-over Hazard	2
9413013	Warning-Crushing Hazard/Fall Hazard	2
9413015	Danger-Electrocution Hazard	2
9413017	Warning-Inspect and Maintain Properly	2
9413019	Warning- Do not extened the extension platform	2
9421031	Warning-Explosion/Burn Hazard	1
9441019	Warning-Recharging in Time	1
9441023	Label- Direction al Arrows	1
9443019	Notice-Charge Time	1
9411033	Danger- Tip-over Hazard –Extension deck	1

Specifications

JCPT3(III) Specification

Height, working maximum	5 m
Height, platform maximum	3 m
Height, stowed maximum	1.65 m
Width	0.7 m
Length	1.14 m
Length with one extension deck, platform extended	1.8 m
Length with two extension deck, platform extended	1.8 m
Maximum load capacity	240 kg (1 person + 160kg tools & materials)
Maximum wind speed	No Windy Conditions / Indoor use only
Wheelbase	0.85 m
Turning radius (outside)	2.5 m
Ground clearance	6 cm
Weight	458kg
Rated Slope	Level Surface
Maximum working slope	2°
Gradeability	30%
Maximum hydraulic pressure	110 bar
Tire size	6" Caster 230 x 80
Platform length	1.14 m
Platform extension length with one extension deck	0.7 m
Platform extension length with two extension deck	0.4 m
Platform width	0.7 m
Stowed, maximum drive speeds	4 km/h
Platform raised, maximum drive speeds	0.8 km/h
Airborne noise emissions	70 dB
Maximum sound level at normal operating workstations (A-weighted)	

Floor loading information

Tire load, maximum	500 kg
Tire contact pressure	983 kg/mm ²
Occupied floor pressure	824 kg/mm ²

Note: Floor loading information is approximate and does not incorporate different option configurations.

It should be used only with adequate safety factors.

Continuous improvement of our products is a DINGLI policy. Product specifications are subject to change without notice or obligation.

Hydraulic Schematic

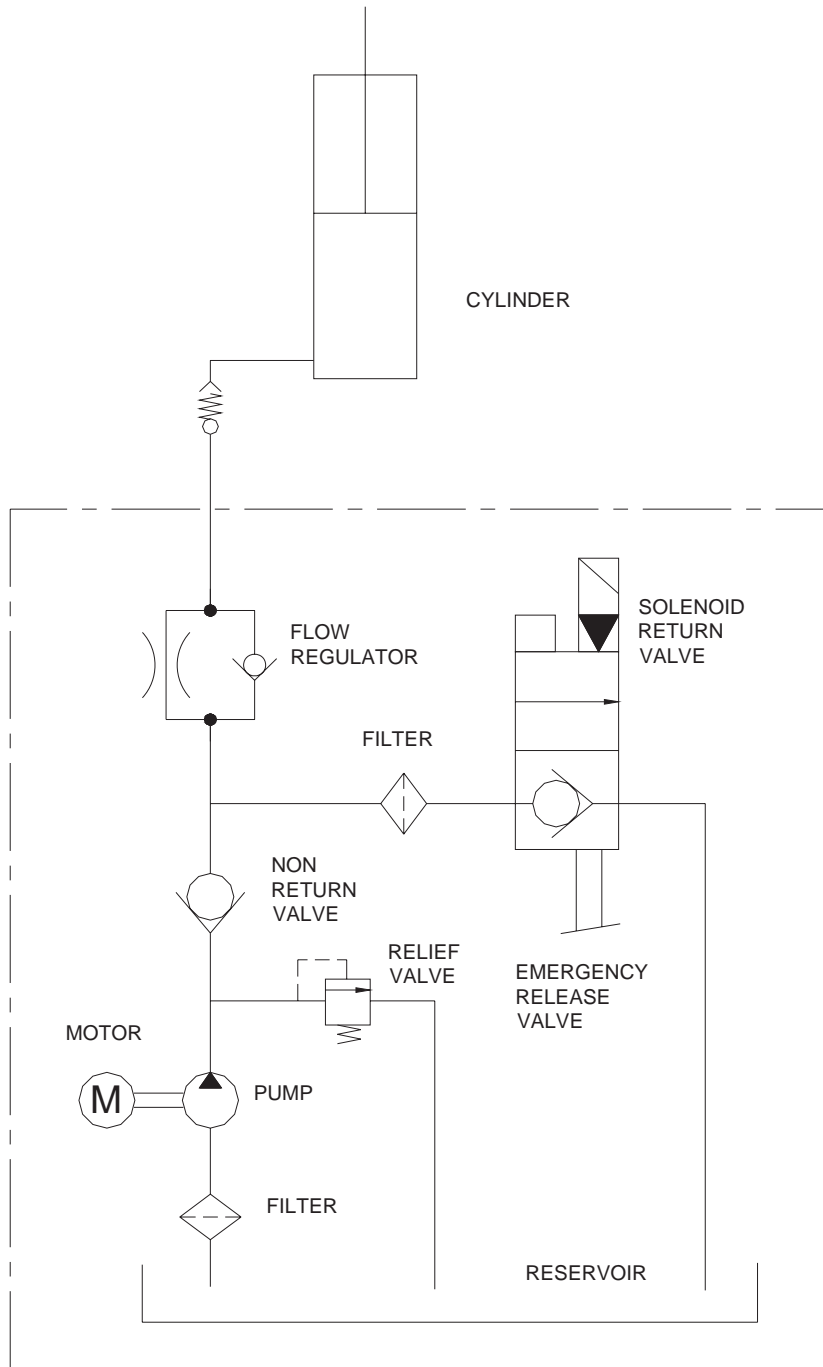

Schematic

Electrical Schematic

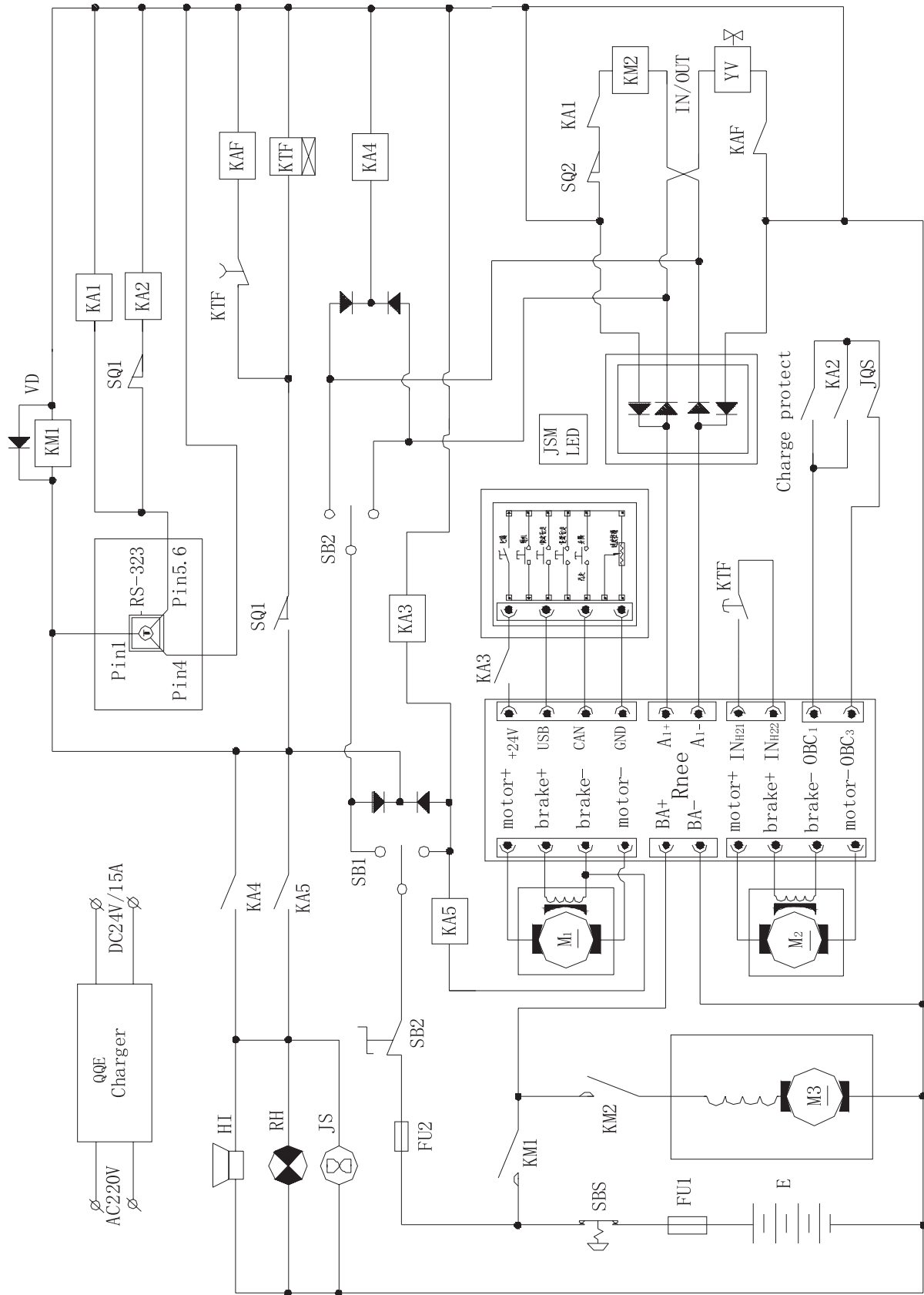

Schematic

No.	Symbol	Description	Q'ty
1	IN/OUT	Controller Box	1
2	YV	Lower Valve Coil	1
3	KTF	Time Relay	1
4	KAF	Intermediate Relay	1
5	RH	Power Light	1
6	KA5	Intermediate Relay	1
7	KA4	Intermediate Relay	1
8	KA3	Intermediate Relay	1
9	KA2	Intermediate Relay	1
10	KA1	Intermediate Relay	1
11	RS323	Slope Sensor	1
12	SQ2	Upper Limited Switch	1
13	SB2	Emergency Stop Switch	1
14	SB1	Key Switch	1
15	SBS	Platform up / down toggle switch	1
16	KM2	Pump Contactor	1
17	KM1	Power Contactor	1
18	FU2	Fuse	1
19	FU1	Fuse	1
20	SBS	Power Emergency Stop Switch	1
21	SQ1	Low Limited Switch	1
22	JQS	Foot Switch	1
23	JS	Hour Meter	1
24	RH	Alarm Beacon	1
25	Hi	Buzzer	1
26	E	Battery	2
27	M3	Hydraulic Pump Motor	1
28	M2	Right Drive Motor	1
29	M1	Left Drive Motor	1
30	JSM	Joystick	1
31	Rnee	Controller Rnee	1
32	QQE	Battery Charger	1

Schematic

Maintenance

Date	Scheduled maintenance undertaken	By

Repairs

Date	Repairs undertaken	By

Examinations / tests

Date	Examinations / tests undertaken	By

Please photocopy this page for your own use, as required

Chassis

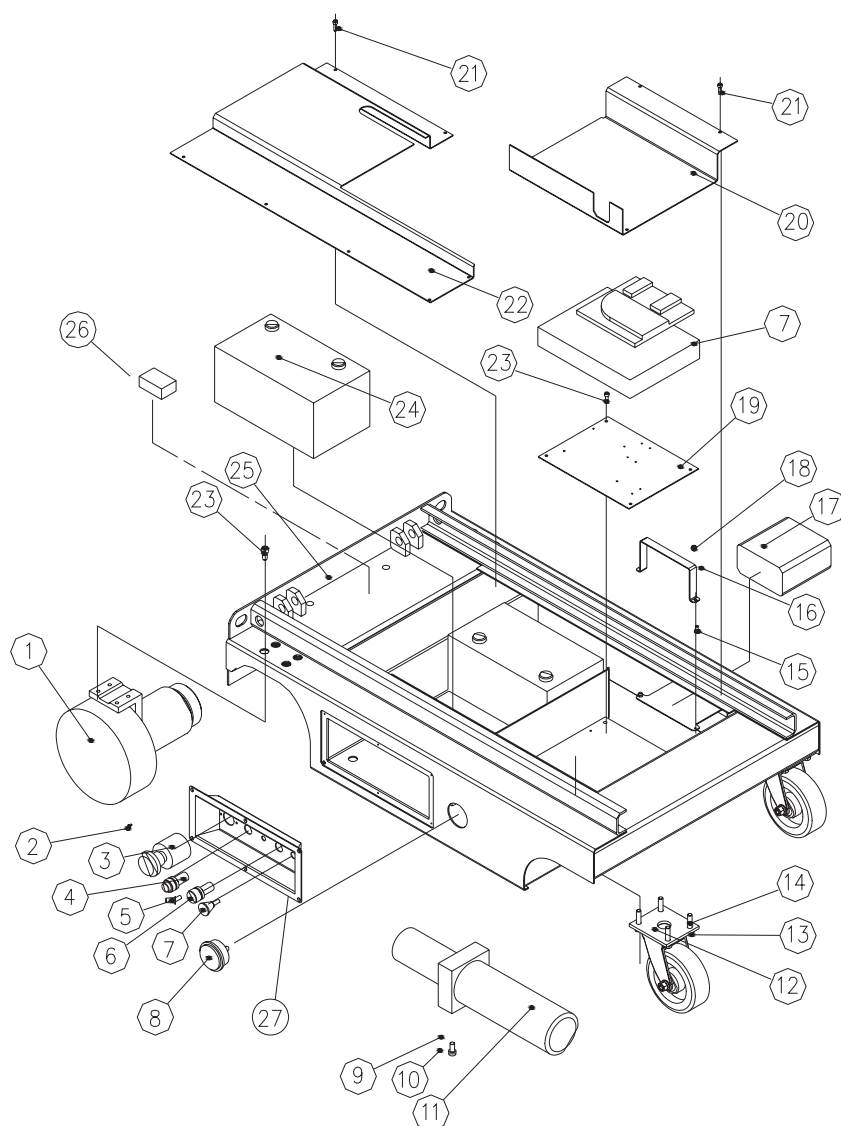

No.	Parts No.	Description	Qty.	No.	Parts No.	Description	Qty.
1		Driving wheel	2	14	GB/T97.1-2000	Washer10	8
2	GB/T70.3-2000	Screw M4x8	10	15	GB70.1-2000	Screw M6x20	2
3		Power breaker	1	16	JCPT5007MQ-00008	Holder	1
4		Key switch	1	17		Charger	1
5		Up / down switch	1	18	GB6170-2000	Nut M6	2
6		Power light	1	19	JCPT5007MQ-00030	Panel	1
7		Emergency lower	1	20	JCPT5007MQ-00001	Cover	1
8		Hour meter	1	21	GB818-2000	Screw M6-15	40
9	GB/T93.1-2000	Washer 10	2	22	JCPT5007MQ-00200	Cover	1
10	GB/T70.1-2000	Screw M10x20	2	23	GB70.1-2000	Screw M8x20	26
11		Pump	1	24	95D31L	Battery	2
12		Caster	2	25	JCPT5007MQ-11000	Frame	1
	JCPT5007MQ-00011	Panel	1	26		Level sensor	1
13	GB/T5783-2000	Bolt M10x20	8	27	JCPT5007MQ-00011	Controller box	1

Scissors Arms Assembly

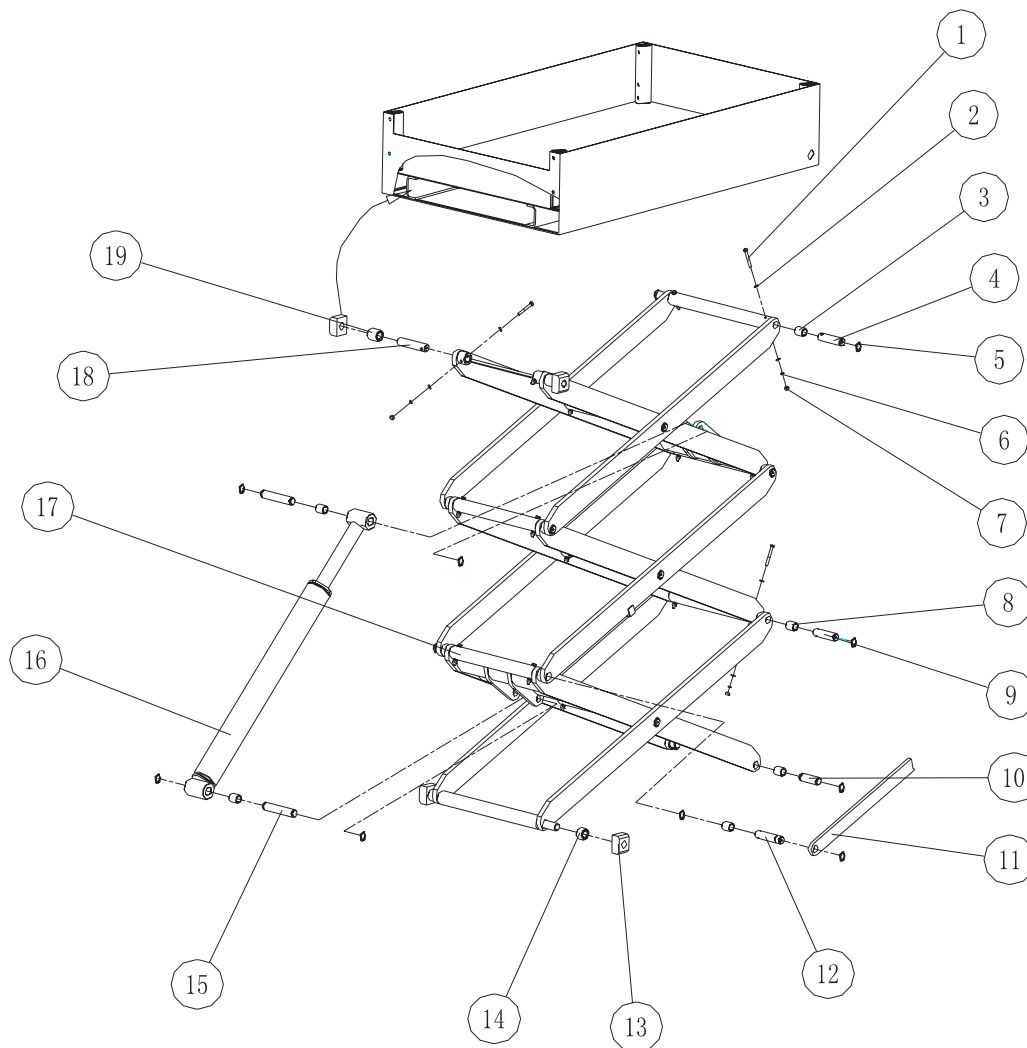

No.	Parts No.	Description	Qty.	No.	Parts No.	Description	Qty.
1	GB/T5780-2000	Bolt M6x50	18	11	JCPT3707M-31012	Safety Arm	2
2	GB/T97.1-2000	Washer 6	36	12	JCPT5007M-31003	Safety Arm Axle	2
3		Bearing2030	6	13	JCPT3707M-31002	Slider	4
4	JCPT5007M-31005	Spindle Axle	2	14	JCPT5007M-31004	Spacer II	2
5	GB894.1	Circlip 20	28	15	JCPT5007M-31008	Lift Cylinder Pin	2
6	GB/T93.1-2000	Washer 6	18	16	JCPT5007M-53100	Lift Cylinder	1
7	GB/T6182-2000	Nut M6	18	17	JCPT5007M-31000	Scissors	1
8		Bearing2028	20	18	JCPT5007M-31001	Slider Pin	2
9	JCPT5007M-31006	Scissors Axle	12	19	JCPT5007M-31002	Spacer I	2
10	JCPT5007M-31007	Pivot Pin	2				

Platform (Draw Gate)

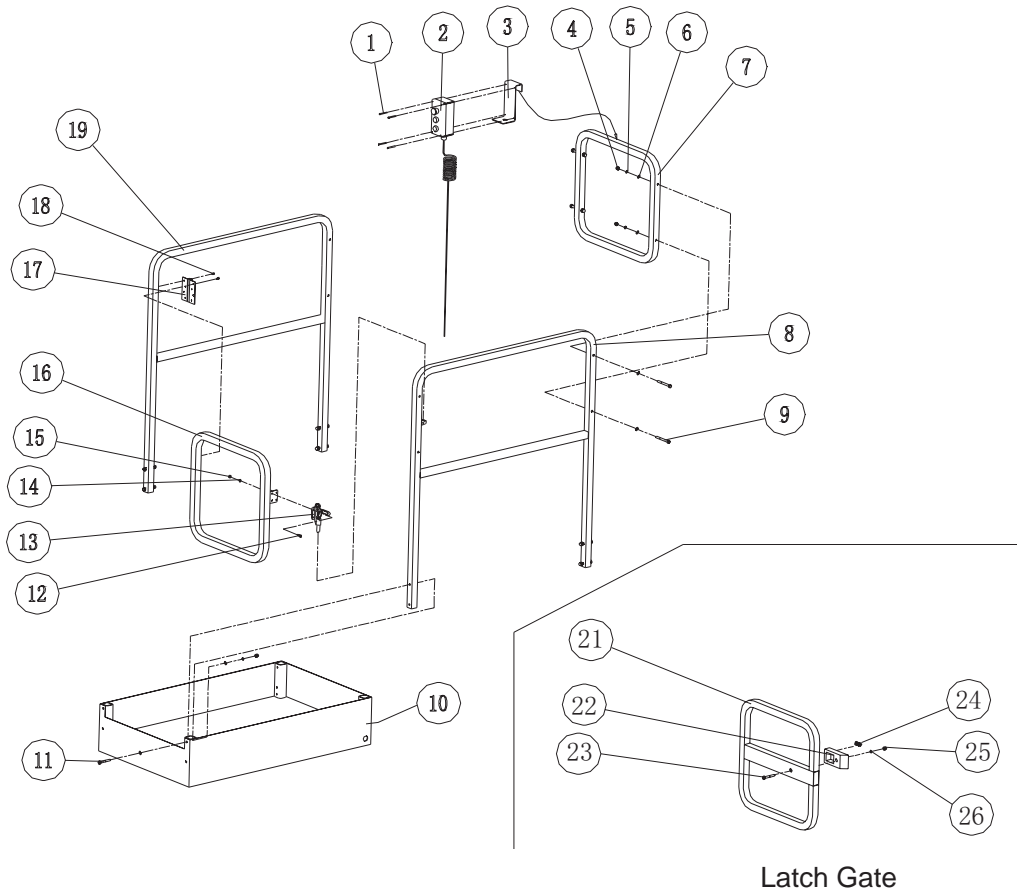

Latch Gate

No	Parts No.	Description	Qty.	No	Parts No.	Description	Qty.
1		Screw M4x30	4	14	GB/T97.1-2000	Washer 6	4
2		Platform Controls	1	15	GB/T6182-2000	Nut M6	4
3	JCPT5007MQ-00100	Platform Controls Carrier	1	16	JCPT3707M-41300	Gate	1
4	GB/T923-1998	Nut M8	12	17		Hinge	2
5	GB/T93.1-2000	Washer 8	12	18	GB/T12618.1-2006	Rivet 4x12	16
6	GB/T97.1-2000	Washer 8	24	19	JCPT5007M-41230	Left Guardrail	1
7	JCPT4507M-41220	Front Guardrail	1				
8	JCPT5007M-41210	Right Guardrail	1	21	JCPT3707M-43300	Gate	1
9	GB/T5780-2000	Bolt M8x75	4	22	JCPT3707M-43001	Lock	1
10	JCPT5007MQ-41100	Platform Deck	1	23	GB/T5780-2000	Screw M6x40	1
11	GB/T5782-2000	Bolt M8x55	8	24	JCPT3707M-43002	Spring	1
12	GB/T70.1-2000	Screw M6x16	4	25	GB/T6182-2000	Nut M6	1
13		Latch	1	26	GB/T97.1-2000	Washer 6	1

Platform (Slide Gate)

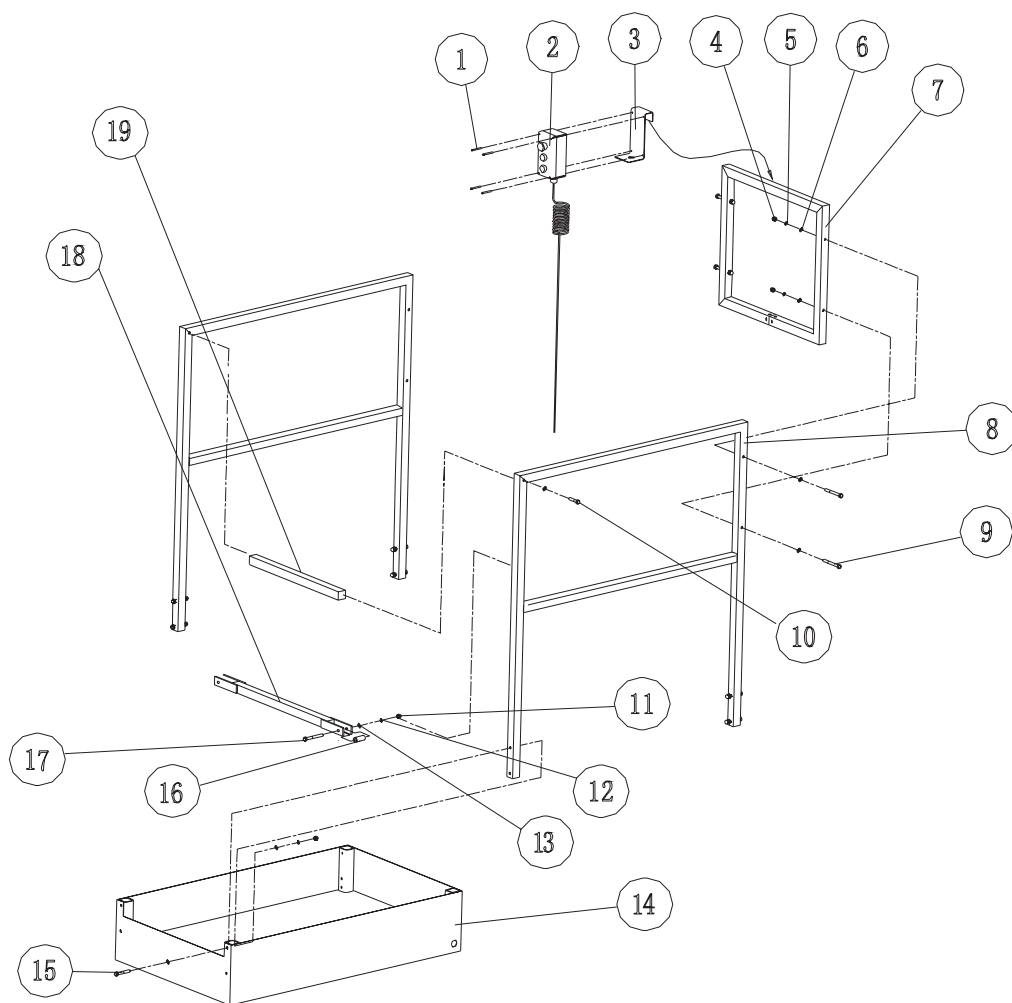

No.	Parts No.	Description	Qty.	No.	Parts No.	Description	Qty.
1		Screw M4x30	4	11	GB/T6182-2000	Nut M6	2
2		Platform Controls	1	12	GB/T97.1-2000	Washer 6	2
3	JCPT5007MQ-00100	Platform Controls Carrier	1	13	GB/T93.1-2000	Washer 6	2
4	GB/T923-1998	Nut M8	12	14	JCPT5007MQ-41100	Platform Deck	1
5	GB/T93.1-2000	Washer 8	12	15	GB/T5782-2000	Bolt M8x55	8
6	GB/T97.1-2000	Washer 8	24	16	JCPT3707M-42001	Roller	2
7	JCPT3707M-42120	Front Guardrail	1	17	GB/T5783-2000	Bolt M6x40	2
8	JCPT5007M-42110	Guardrail	1	18	JCPT3707M-42010	Gate Bar	1
9	GB/T5780-2000	Bolt M8x75	4	19	JCPT3707M-42020	Gate head	1
10	GB/T5783-2000	Bolt M8x40	2				

One Extension Platform

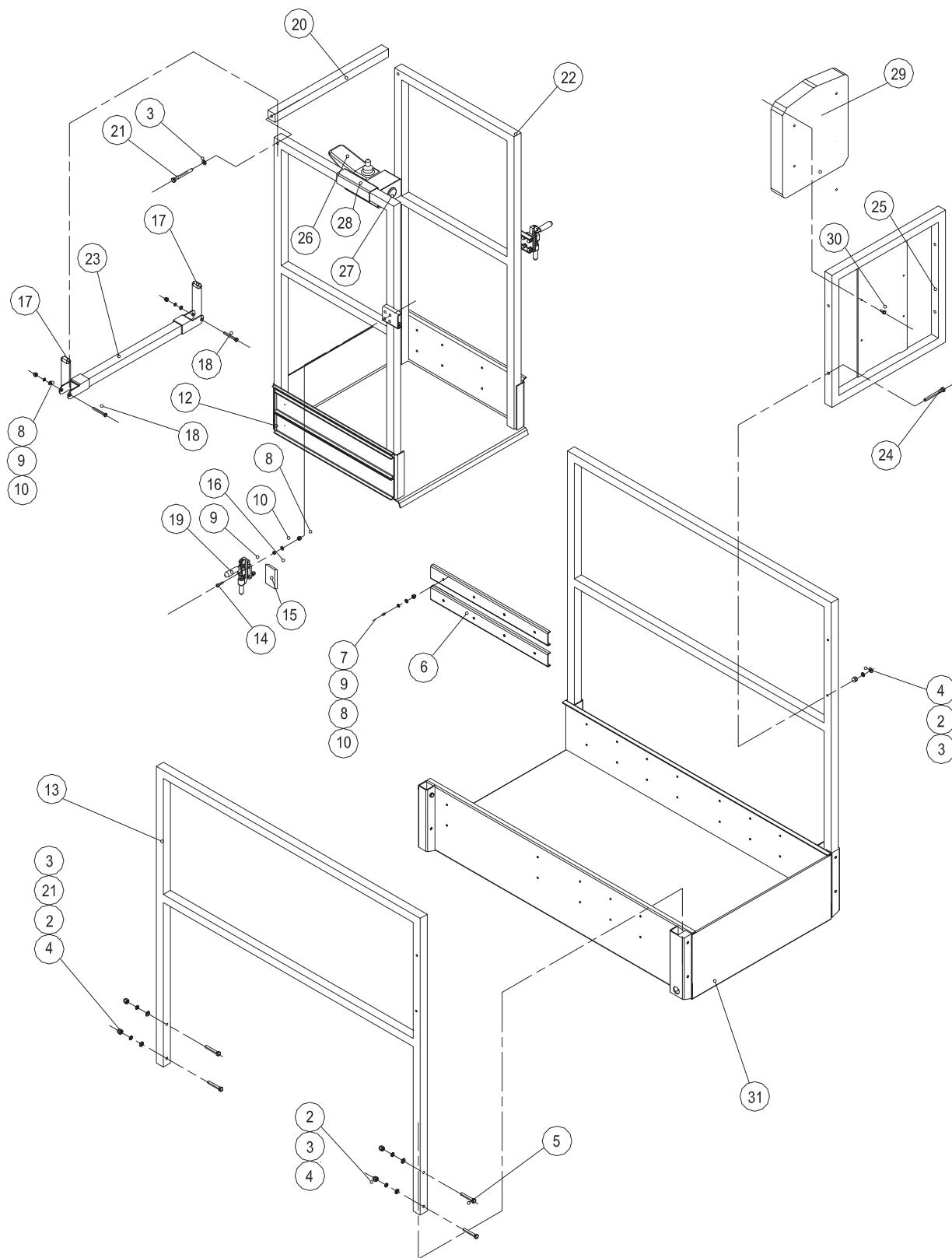

Part Manual

No.	Parts No.	Description	Qty	No.	Parts No.	Description	Qty
2	GB97.1-2000	Flat washer8	24	20	JCPT5007MQ-44420	Bar	1
3	GB93.1-2000	Spring washer 8	24	21	GB5782-2000	Bolt M8X45	20
4	GB923-1998	Nut M8	24	22	JCPT5007MQ-44410	Side Rail	2
5	GB5782-2000	Bolt M6x70	4	23	JCPT5007MQ-44401	Slide bar	1
8	GB97.1-2000	Flat washer 6	48	24	GB5782-2000	Bolt M8X75	4
9	GB93.1-2000	Spring washer 6	48	25	JCPT5007MQ-44520	Back bar	1
10	GB923-1998	Nut M6	48	26		Controller	1
12	JCPT5007MQ-44400	Front extension platform	1	27		Switch	1
13	JCPT5007MQ-44300	Fixed rail	2	28		Seat	1
14	GB/T818-2000	Screw M6x20	4	29		Tool box	1
15	JCPT5007MQ-43404	Block seat	4	30	GB5782-2000	Bolt M6x15	4
16	JCPT5007MQ-43405	Block	4	31	JCPT5007MQ-44100	Fixed platform	1
17	JCPT4507M-42001	Wheel	4	32	7601T-20"	Slide rail	4
18	GB5782-2000	Bolt M6X50	4	33	GB819-85	Screw M6X15	32
19		Handle	2				

Two Extension Platform

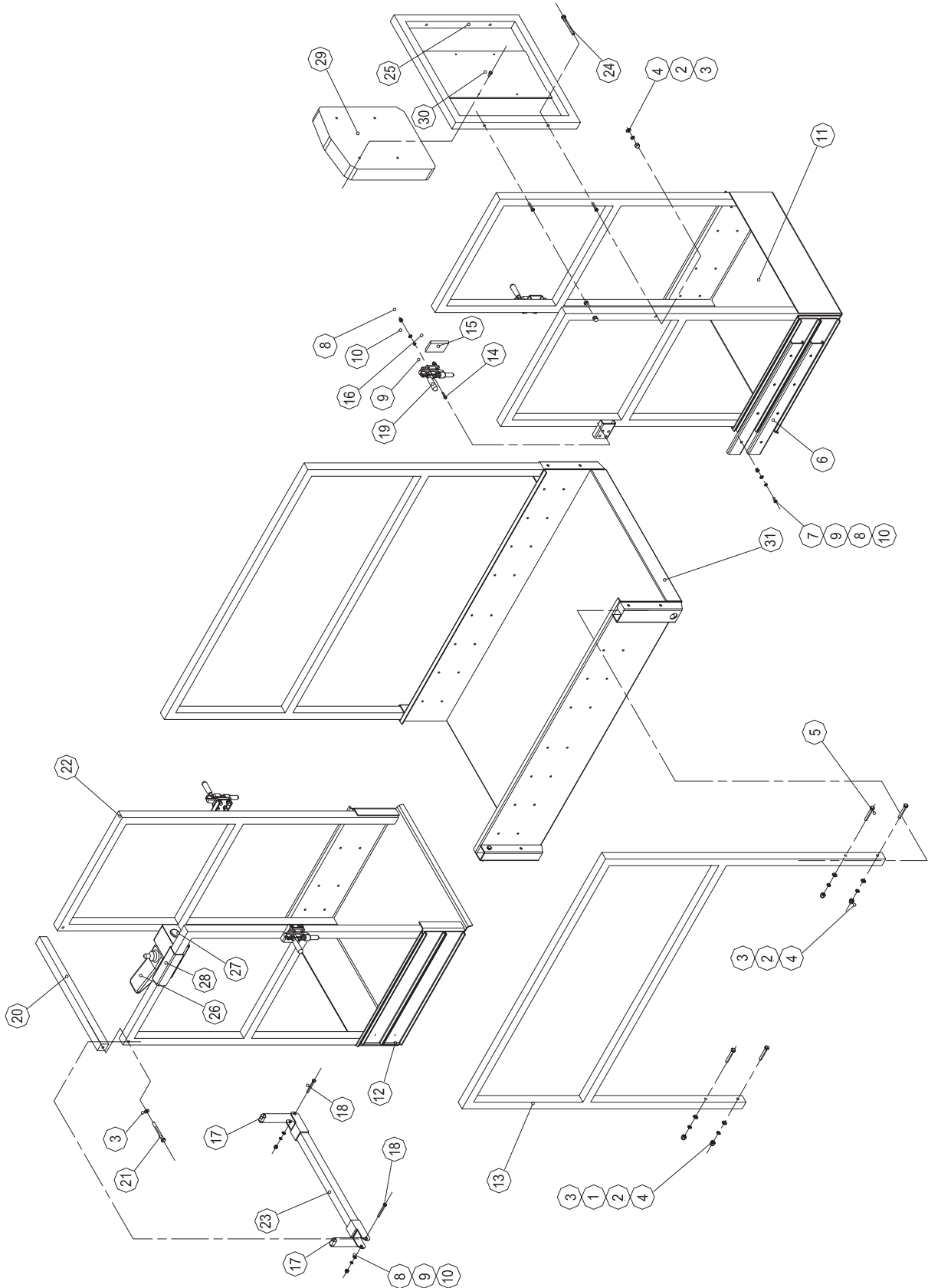

Part Manual

No.	Parts No.	Description	Qty	No.	Parts No.	Description	Qty
1	GB5782-2000	Bolt M8X45	20	17	JCPT4507M-42001	Wheel	4
2	GB97.1-2000	Flat washer8	72	18	GB5782-2000	Bolt M6X50	4
3	GB93.1-2000	Spring washer 8	72	19		Handle	2
4	GB923-1998	Nut M8	72	20	JCPT5007MQ-44420	Bar	1
5	GB5782-2000	Bolt M8X75	4	21	JCPT5007MQ-44410	Side Rail	2
6	7601T-20"	Slide rail	4	22	JCPT5007MQ-44401	Slide bar	1
7	GB819-85	Screw M6X15	32	23	JCPT5007MQ-44520	Back bar	1
8	GB97.1-2000	Flat washer 6	96	24		Controller	1
9	GB93.1-2000	washer 6	96	25		Switch	1
10	GB923-1998	Nut M6	96	26		Seat	1
11	JCPT5007MQ-44200	Back extension platform	2	27		Tool box	1
12	JCPT5007MQ-44400	Front extension platform	1	28	GB5782-2000	Bolt M6x15	4
13	JCPT5007MQ-44300	Fixed rail	2	29	JCPT5007MQ-44100	Fixed platform	1
14	GB/T818-2000	Screw M6x20	4	30	GB5782-2000	Bolt M6x45	20
15	JCPT5007MQ-43404	Block seat	4	31	GB5782-2000	Bolt M6x70	1
16	JCPT5007MQ-43405	Block	4				

Inspection and Repair Log

Date	Comments